

# An Overview of the ASTM Continuity of Care Record (CCR)

Web-enabling Health Information  
To Improve Quality and Safety of Care, and to  
Help Drive Out Unnecessary Costs



American Academy of Pediatrics  
DEDICATED TO THE HEALTH OF ALL CHILDREN™



# Background

- This presentation was prepared by David C. Kibbe, MD MBA for educational purposes only. It may be reproduced without asking further permission as long as citations are made as to the origins of the content herein presented.
- Questions may be directed to  
David C. Kibbe, MD MBA  
American Academy of Family Physicians  
[dkibbe@aafp.org](mailto:dkibbe@aafp.org)  
[www.centerforhit.org](http://www.centerforhit.org)  
919-960-5290 or 913-205-7968

# Background, continued

- The CCR is a published, open, and royalty-free IT standard developed under the auspices of ASTM by volunteers, and is formally referred to as “E2369-06, Standard Specification for the Continuity of Care Record (CCR).”
- All components of the standard can be purchased from ASTM for \$100 total. To purchase, visit the ASTM website [www.astm.org](http://www.astm.org) and enter "E2369" into the search box. Purchase of the standard is not required for its use, but we strongly encourage developers and programmers who will utilize the CCR standard in their work to make a one-time purchase of the standard.
- Individuals may also receive a free copy of the CCR standard by joining the E31 Healthcare Informatics Committee of ASTM. The cost to join is \$75 per year and as a member you are entitled to a free Volume of Standards (the E31 standards are found in Volume 14.01) . To join, visit [www.astm.org](http://www.astm.org), click "membership" and then click "Join ASTM International". Remember to indicate that you want to join Committee E31 and the E31.28 Electronic Health Record Subcommittee and to select the virtual format Volume 14.01.
- None of the medical professional societies involved in the development of the CCR standard receive revenues or any profit whatsoever from the adoption of the standard.

# This presentation will answer these questions

- What is the CCR standard, and what problems has it been designed to solve?
- Who is responsible for the development and maintenance of the CCR standard?
- How and in what situations can the use of the CCR standard offer opportunities for improving quality, safety, or cost efficiency to employers and employees?

# The Problem

# The problems that the CCR standard is designed to address

- Let's start with a few simple questions. In the 'information age' :
  - Why must I fill out a paper form on a clipboard each time I see a new doctor, clinic, or ER?
    - Why can't they remember me and my family? ( Jiffy Lube remembers me and our car! )
  - Why can't my health information be stored electronically, like my banking information?
    - When I travel or have an emergency, why isn't my health information available to me on the spot?
  - Why can't I get my kids' immunization records electronically?
    - It's a real inconvenience to get paper copies from the doctor for school and camps each time.
  - Is it necessary to keep Dad's medication list, along with his allergy information, on paper stored in the doctors' office or hospital records room?
    - Doesn't this increase the likelihood of mistakes and errors with his medications?
    - Wouldn't it be safer if both the pharmacy and the doctor had this information online?
  - My diabetes and high blood pressure both require careful monitoring, and I'm trying to lose weight at the same time my medications are being adjusted.
    - Isn't there some way I can use my desktop computer and personal health information to track my progress and give me confidence I've got things under control?
  - Even though I'm perfectly healthy, I know my family has a history of some medical conditions.
    - Why can't I get a health risk assessment online, and then monitor what I need to do to reduce my risks?
  - When I want a quote on car insurance or a home mortgage, it's easy to get one on the Internet.
    - Why can't I shop around for medications or medical equipment the same way?
    - How can I be expected to be a good consumer of health care or health related medical products and services when I can't match who I am medically with the offerings in the marketplace?

# The problems that the CCR standard is designed to address

Although health data and information are increasingly captured and stored in electronic format - by computers in doctors' offices, hospitals, health plans, pharmacies, laboratories, radiology centers, etc. - these data remain generally "locked in." The health care industry is characterized by proprietary information systems that have been often described as "data islands."

Computer systems that cannot efficiently mobilize digital health data make it difficult to improve health care quality or make gains in productivity. If health information must be transferred by fax or paper, opportunities are lost that could automate routine processes or workflows; inform patients, consumers, and doctors of health risks or expected benefits; and deliver clinical decision support at or near the point of care. In general, the health care industry is at a stage compare to the banking industry about 10 years ago with respect to connectivity and interoperability.

Although there is an abundance of health IT standards, until the CCR standard there was no agreement on a means of exchanging basic, important clinical summary health information (or components of same) between computers using software from different vendors, on the same, or different, networks.

From the patient's perspective:

Data, data everywhere, but no access to it, and almost no tools to turn it into information I can use.

Proprietary software applications that can't "talk" to each other, even on the most mundane level.

Patients/consumers completely dependent upon providers and health plans for data access.

To have an effect upon quality, safety, or efficiency, health care data must be personal, portable, and accessible where and when it is needed. In a word, health data must be networkable.

The CCR standard - a simple idea whose time has come:  
personal, private, portable patient-centered summary health data,  
in a standard format, able to be exchanged among care providers  
and between providers and patients

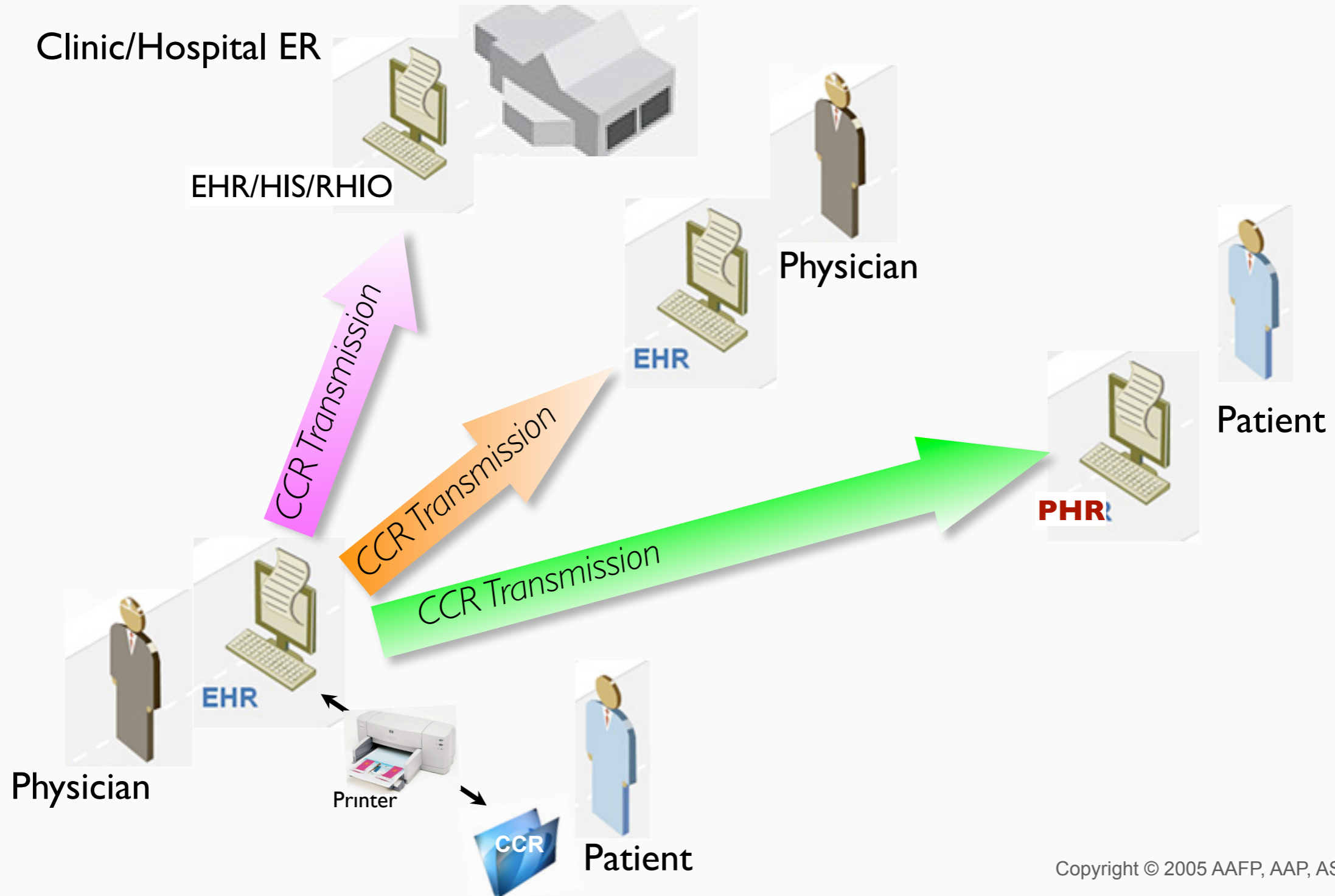

# Some basic definitions

- **EHR - electronic health record**
  - A comprehensive suite of software applications used by providers in ambulatory care medical practices that generally includes billing/claims, scheduling, and clinical information management (EMR) modules. An *integrated* EHR is supplied by a single vendor. Ambulatory medical practice and hospital EHRs are very different from one another, and vendor cross-over is unusual.
- **EMR - electronic medical record**
  - A software application for managing the clinical processes of patient care, documentation, decision support, e-prescribing, etc. This is an older term than EHR, and is less often used today. In medical offices, an EMR is usually interfaced with a billing software solution.
- **PHR - personal health record**
  - A software application that allows the individual patient/consumer to enter, store, and organize personal health information. Also used to describe a *view* of the data in a provider's EHR made available to patients, e.g. via a web portal.
- **HIS - health information system**
  - Used to describe all of the components of a hospital's or integrated delivery system's information systems. *Legacy* HIS components refer to those older, pre-Internet components, e.g. mainframe or mini-computer hardware and the software that runs on it.

The Continuity of Care Record standard is a content **and** structure standard that uses eXtensible Markup Language (XML). A CCR file is a “snap shot” of a patient’s medical history that can be created from one, or many, sources, e.g. EHRs, PHRs, health plans, etc.

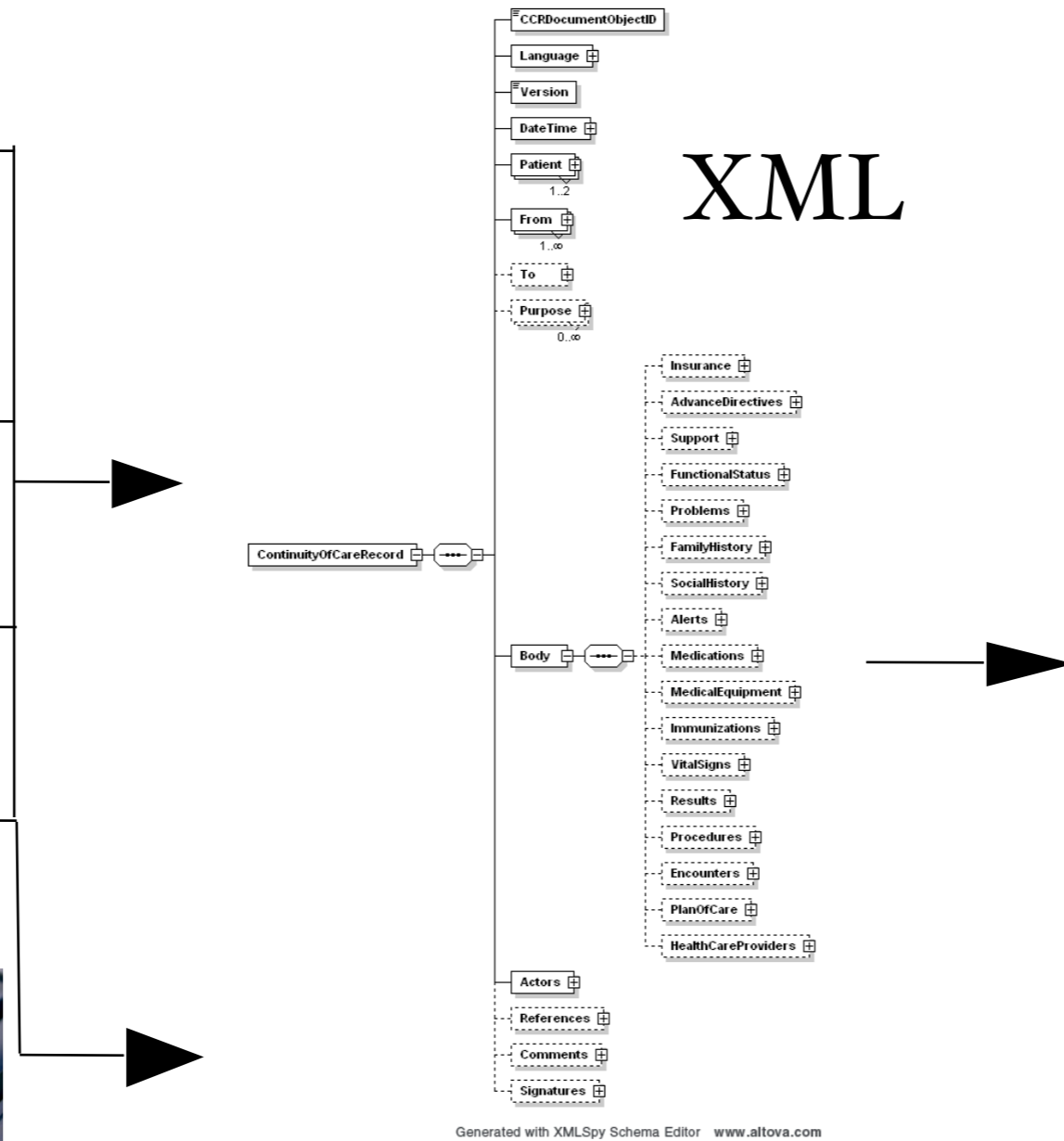
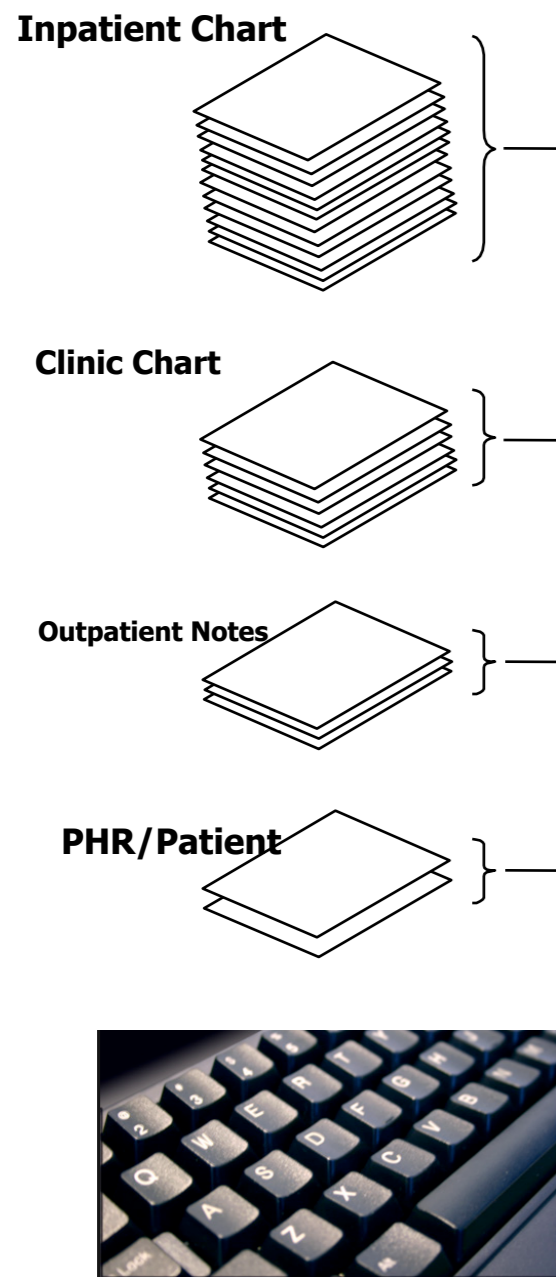

Continuity of Care Record <https://www.solventus.com/Aquifer/ReportContainer.aspx?control=...>

### Continuity of Care Record

Date Created: Mon Aug 22, 2005 at 03:45 PM UTC  
 From: Dr. David Kibbe  
 Center for Health Information Technology - AAFP  
 Solventus CCR Generation Tool V1.0

To:  
 Purpose:

#### Patient Demographics

Name	Date of Birth	Gender	Identification Numbers	Address / Phone
John B Doqit	Jan 16, 1938	Male	SSN: 888-88-8888	

#### Alerts

Type	Date	Code	Description	Reaction	Source
Allergy	Initial Occurrence: Jan 01, 1970	272.2 ( ICD9-CM)	Penguins	-	Dr. John Gray
Allergy	Initial Occurrence: Mar 29, 2005	995.2 ( ICD9-CM)	Sulfa	-	Dr. John Gray

#### Advance Directives

Type	Date	Description	Status	Source
CPR Status	Recorded Date: Jul 01, 2005	Cardioversion Only	Current and Verified	Dr. John Gray

#### Problems

Type	Date	Code	Description	Status	Source
Diagnosis	Onset: Apr 01, 1999	402.11 ( ICD9-CM)	Congestive Heart Failure	Active	Dr. John Gray
Diagnosis	Onset: Mar 01, 1984	250.02 ( ICD9-CM)	Diabetes Mellitus	Active	Dr. John Gray
Diagnosis	Onset: Aug 08, 1990	403.10 ( ICD9-CM)	Hypertension	Active	Dr. John Gray
Diagnosis	Onset: Jan 25, 2003	410.80 ( ICD9-CM)	Myocardial Infarction	Active	Dr. John Gray
Symptom	Onset: Jul 14, 2005	585 ( ICD9-CM)	CHRONIC RENAL FAILURE		Dr. John Gray

#### Procedures

Type	Date	Code	Description	Location	Substance	Method	Position	Site	Status	Source
------	------	------	-------------	----------	-----------	--------	----------	------	--------	--------

#### Medications

Medication	Date	Form	Strength	Quantity	SIG	Indications	Instruction	Refills	Source
furosemide	Prescription Date: Dec 09, 2003	tablet	80	100 tablet	1 tablet PO bid		May increase dose by one tablet qd prn	0	Dr. John Gray

1 of 3 8/22/05 11:54 AM

documents, data  
EHR, HIS

structured data

flexible expression of  
structured data

# The CCR standard's content

The following sections of a CCR xml file are available, and may be used in any combination.

- demographics
- insurance information
- diagnosis/problem list
- alerts/allergies
- medications
- immunizations
- social history
- family history
- functional status
- advance directives
- encounters
- procedures
- care plan
- vital signs
- laboratory results
- medical equipment
- providers
- support persons

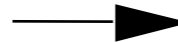

Continuity of Care Record <https://www.solventus.com/Aquifer/ReportContainer.aspx?control=...>

**Continuity of Care Record**

Date Created: Mon Aug 22, 2005 at 03:45 PM UTC  
From: Dr. David Kibbe  
Center for Health Information Technology - AAFP  
Solventus CCR Generation Tool V1.0  
To:  
Purpose:

**Patient Demographics**

Name	Date of Birth	Gender	Identification Numbers	Address / Phone
John B Doqi	Jan 16, 1938	Male	SSN: 888-88-8888	

**Alerts**

Type	Date	Code	Description	Reaction	Source
Allergy	Initial Occurrence: Jan 01, 1970	272.2 (ICD9-CM)	Penguins	-	Dr. John Gray
Allergy	Initial Occurrence: Mar 29, 2005	995.2 (ICD9-CM)	Sulfa	-	Dr. John Gray

**Advance Directives**

Type	Date	Description	Status	Source
CPR Status	Recorded Date: Jul 01, 2005	Cardioversion Only	Current and Verified	Dr. John Gray

**Problems**

Type	Date	Code	Description	Status	Source
Diagnosis	Onset: Apr 01, 1999	402.11 (ICD9-CM)	Congestive Heart Failure	Active	Dr. John Gray
Diagnosis	Onset: Mar 01, 1984	250.02 (ICD9-CM)	Diabetes Mellitus	Active	Dr. John Gray
Diagnosis	Onset: Aug 08, 1990	403.10 (ICD9-CM)	Hypertension	Active	Dr. John Gray
Diagnosis	Onset: Jan 25, 2003	410.80 (ICD9-CM)	Myocardial Infarction	Active	Dr. John Gray
Symptom	Onset: Jul 14, 2005	585 (ICD9-CM)	CHRONIC RENAL FAILURE		Dr. John Gray

**Procedures**

Type	Date	Code	Description	Location	Substance	Method	Position	Site	Status	Source
------	------	------	-------------	----------	-----------	--------	----------	------	--------	--------

**Medications**

Medication	Date	Form	Strength	Quantity	SIG	Indications	Instruction	Refills	Source
furosemide	Prescription Date: Dec 09, 2003	tablet	80	100 tablet	1 tablet PO bid		May increase dose by one tablet qd prn	0	Dr. John Gray

1 of 3 8/22/05 11:54 AM

A segment of  
source (programming)  
code from a  
CCR xml file

**Digoxin 0.125mg, 1 PO qDay, #90, 5 refills.**

```
<Medications>
  <Medication>
    <Description>
      <Text>Digoxin 0.125mg, 1 PO qDay, #90, 5 refills</Text>
    </Description>
    <Product>
      <ProductName>Digoxin</ProductName>
      <Strength>
        <Value>0.125</Value>
        <Units>mg</Units>
      </Strength>
    </Product>
    <Quantity>
      <Value>90</Value>
    </Quantity>
    <Directions>
      <Direction>
        <Dose>
          <Value>1</Value>
        </Dose>
        <Route>
          <Text>po</Text>
        </Route>
        <Frequency>
          <Value>qd</Value>
        </Frequency>
      </Direction>
    </Directions>
    <Refills>
      <Refill>
        <Number>5</Number>
      </Refill>
    </Refills>
  </Medication>
```

A CCR xml file expressed as a web page

Continuity of Care Record

Getting Started Latest Headlines Map Weather

<https://www.solventus.com/Aquifer/ReportContainer.aspx?control=ShowSessionXmlContro>

## Continuity of Care Record

**Date Created:** Mon Aug 22, 2005 at 03:45 PM UTC  
**From:** Dr. David Kibbe  
 Center for Health Information Technology - AAFP  
 Solventus CCR Generation Tool V1.0  
**To:**  
**Purpose:**

### Patient Demographics

Name	Date of Birth	Gender	Identification Numbers	Address / Phone
John B Doqit	Jan 16, 1938	Male	SSN: 888-88-8888	

### Alerts

Type	Date	Code	Description	Reaction	Source
Allergy	Initial Occurrence: Jan 01, 1970	272.2 ( ICD9-CM)	Penguins	-	Dr. John Gray
Allergy	Initial Occurrence: Mar 29, 2005	995.2 ( ICD9-CM)	Sulfa	-	Dr. John Gray

### Advance Directives

Type	Date	Description	Status	Source
CPR Status	Recorded Date: Jul 01, 2005	Cardioversion Only	Current and Verified	Dr. John Gray

### Problems

Type	Date	Code	Description	Status	Source
Diagnosis	Onset: Apr 01, 1999	402.11 ( ICD9-CM)	Congestive Heart Failure	Active	Dr. John Gray
Diagnosis	Onset: Mar 01, 1984	250.02 ( ICD9-CM)	Diabetes Mellitus	Active	Dr. John Gray
Diagnosis	Onset: Aug 08, 1990	403.10 ( ICD9-CM)	Hypertension	Active	Dr. John Gray
Diagnosis	Onset: Jan 25, 2003	410.80 ( ICD9-CM)	Myocardial Infarction	Active	Dr. John Gray
Symptom	Onset: Jul 14, 2005	585 ( ICD9-CM)	CHRONIC RENAL FAILURE		Dr. John Gray

### Procedures

Type	Date	Code	Description	Location	Substance	Method	Position	Site	Status	Source
------	------	------	-------------	----------	-----------	--------	----------	------	--------	--------

### Medications

Medication	Date	Form	Strength	Quantity	SIG	Indications	Instruction	Refills	Source
furosemide	Prescription Date: Dec 09, 2003	tablet	80	100 tablet	1 tablet PO bid		May increase dose by one tablet qd prn shortness of breath.	0	Dr. John Gray
metformin	Prescription Date: Mar 29, 2005	tablet, extended release	500	100 tablet	1 tablet PO bid		Hold dose if patient becomes markedly light headed.	0	Dr. John Gray
metoprolol	Prescription Date: Mar 29, 2005	tablet	100	100 tablet	1 tablet PO tid		Hold dose if Systolic Blood Pressure drops below 100, or Diastolic Blood Pressure drops below 50.	0	Dr. John Gray

Done www.solventus.com

# What the Continuity of Care Record Standard is NOT

- The CCR standard is not a software application, not an EHR or a PHR software program (although designed to be used by both).
- The CCR xml file produced using the standard is not a longitudinal record of everything that the patient/consumer has experienced in the doctor's office or hospital over his or her lifetime.
  - Although some sections of the CCR, e.g. immunizations, may record accumulated health care experiences
  - The CCR is intended to be a "snap shot" of the current health care experience of the patient and can point to more sources of more complete or older data
- The CCR is also not
  - A discharge summary from a hospital
  - An electronic version of an established or traditional medical document

# How the Continuity of Care Record standard uses W3C Compliant XML to translate between different EHRs, HIS, PHRs

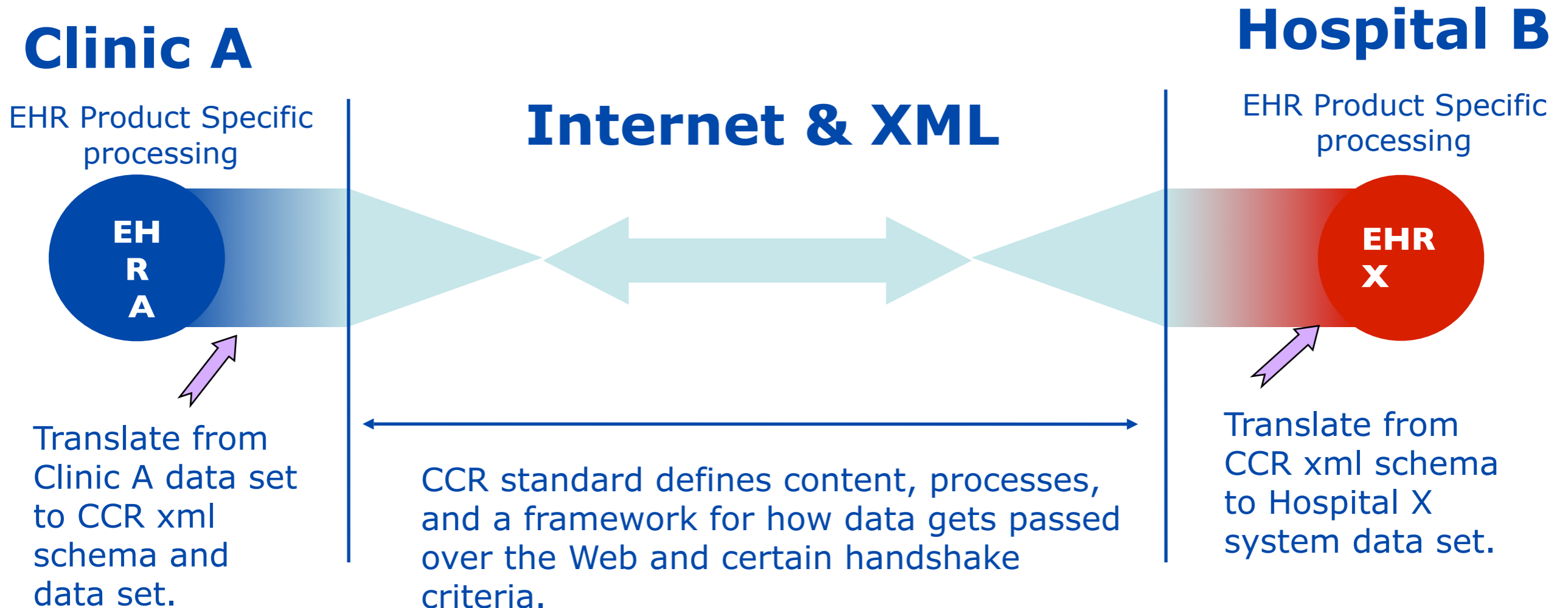

# In a nutshell

- Think of the CCR standard as a technology to collect personal summary health information - such as diagnoses, medications, allergies, and insurance info - and organize this in a single patient-centric XML file that permits:
  - Expression of the information as a web page, a Microsoft Word document, or an Adobe pdf document for viewing on a computer screen, which may then be printed out on paper. (Paper is sometimes very useful!)
  - Secure carriage and transmission of the electronic file via physical transport media, e.g. USB thumb drive, cell phone, CD ROM, or smart card.
  - Secure transmission of the electronic file via a network, e.g. LAN, T1 line, or the Internet.
  - Creation, editing, management, and reporting of the data using both proprietary electronic health records (EHRs) and (nearly) free desktop computing software, e.g. web forms, pdf forms, Firefox plug-in, and other familiar applications, as well as commercial PHRs.
  - Viewing, interpretation, and exchange of the CCR file contents by different, proprietary software applications (the definition of interoperability).

# The People and Organizations

# The CCR standard Sponsors

CCR development and maintenance involves a consortium of not-for-profit sponsors, including the most well-known organizations representing US physicians and medical specialties

- ASTM International
- Massachusetts Medical Society (MMS)
- HIMSS
- American Academy of Family Physicians (AAFP)
- American Academy of Pediatrics (AAP)
- American Medical Association (AMA)
- Patient Safety Institute
- American Health Care Association (AHCA)
- National Association for the Support of LTC
- Mobile Healthcare Alliance (MoHCA)
- Medical Group Management Association (MGMA)
- American Academy of Neurology (AAN)
- American College of Obstetrics and Gynecology (ACOG)
- American Osteopathic Association (AOA)
- American Psychiatric Association (APA)

# ASTM E.2369-06

## Continuity of Care Record Standard

- Standard was published in January, 2006 (**E.2369-06**) by ASTM International, the world's largest standard development and maintenance organization. ASTM is ANSI-accredited, and in addition to health care IT also develops standards used in the avionics, petroleum, air quality, tire, and many other industries.
- Next release underway
  - Comprehensive HIV Coverage (Clinical Trial Qualification, Participation, and Tracking)
  - GYN, Pregnancy, Prenatal, Perinatal, Neonatal, and Lactation Coverage
  - Security and Digital Signature
  - Object Support for Cost and Expense Data (Per Event and Cumulative)
  - Tightening of Vocabulary Restrictions (coordinating with NCPDP on ePrescribing)
- Harmonization with other HIT standards
  - CCR/CDA - CCD (an effort to express the CCR standard content within the framework of the HL7 CDA standard for document exchange in large enterprises )
  - NCPDPScript (the script standard for e-prescribing use, soon to become an XML version)
  - X12 (Claim, Eligibility, and EOB)

Integration of the CCR into EHR and PHR products is well underway through the *CCR Acceleration Group*, an open industry alliance of approximately 75 companies















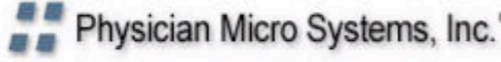



http://www.solventus.com/aafpsa\_2005\_ccr\_gallery.htm

weather Tech Movies MedCommons CCR Gallery Torrent Sports CCR Validator CCHIT vtiger CHiT Ian PHR On The Ave

AAFP Scientific Assembly 2005 C... Google News AT&T Communications Inc. - AT&...

**AAFP's Center for Health Information Technology**  
Assisting Office-Based Clinicians with Health Information Technology

## CCR-Compatible Product Gallery

	View CCR: <a href="#">XML</a> <a href="#">HTML</a> <a href="#">PDF</a> <a href="#">Edit CCR</a>		View CCR: <a href="#">XML</a> <a href="#">HTML</a> <a href="#">PDF</a> <a href="#">Edit CCR</a>
	View CCR: <a href="#">XML</a> <a href="#">HTML</a> <a href="#">PDF</a> <a href="#">Edit CCR</a>		View CCR: <a href="#">XML</a> <a href="#">HTML</a> <a href="#">PDF</a> <a href="#">Edit CCR</a>
	View CCR: <a href="#">XML</a> <a href="#">HTML</a> <a href="#">PDF</a> <a href="#">Edit CCR</a>		View CCR: <a href="#">XML</a> <a href="#">HTML</a> <a href="#">PDF</a> <a href="#">Edit CCR</a>
	View CCR: <a href="#">XML</a> <a href="#">HTML</a> <a href="#">PDF</a> <a href="#">Edit CCR</a>		View CCR: <a href="#">XML</a> <a href="#">HTML</a> <a href="#">PDF</a> <a href="#">Edit CCR</a>
	View CCR: <a href="#">XML</a> <a href="#">HTML</a> <a href="#">PDF</a> <a href="#">Edit CCR</a>		View CCR: <a href="#">XML</a> <a href="#">HTML</a> <a href="#">PDF</a> <a href="#">Edit CCR</a>
	View CCR: <a href="#">XML</a> <a href="#">HTML</a> <a href="#">PDF</a> <a href="#">Edit CCR</a>		View CCR: <a href="#">XML</a> <a href="#">HTML</a> <a href="#">PDF</a> <a href="#">Edit CCR</a>
	View CCR: <a href="#">XML</a> <a href="#">HTML</a> <a href="#">PDF</a> <a href="#">Edit CCR</a>		View CCR: <a href="#">XML</a> <a href="#">HTML</a> <a href="#">PDF</a> <a href="#">Edit CCR</a>
	View CCR: <a href="#">XML</a> <a href="#">HTML</a> <a href="#">PDF</a> <a href="#">Edit CCR</a>		View CCR: <a href="#">XML</a> <a href="#">HTML</a> <a href="#">PDF</a> <a href="#">Edit CCR</a>
	View CCR: <a href="#">XML</a> <a href="#">HTML</a> <a href="#">PDF</a> <a href="#">Edit CCR</a>		View CCR: <a href="#">XML</a> <a href="#">HTML</a> <a href="#">PDF</a> <a href="#">Edit CCR</a>

# Other pertinent facts about the Continuity of Care Record standard

- The CCR standard was among those endorsed by ANSI-HITSP (a federally funded effort to harmonize and choose standards for EHRs and PHRs) and recommended in June, 2006 to AHIC, chaired by Secretary Michael Leavitt at HHS, for potential use as the basis of Medicare PHRs.
- The CCR standard was among those endorsed for use in national PHR efforts by a recent AHIP workgroup under the direction of Accenture (AHIP = America's Health Insurance Plans, a large health plan membership organization).
- Numerous RHIOs (regional health information organization) and community-based health information exchange projects have specified the CCR standard for use, including RHIOs in Maine and Colorado.
- The CCR standard is being deployed in a CCR-based PHR service at the New Orleans Department of Health for the purposes of supplying hurricane evacuees with their personal health records on USB drives. To date, over 6,000 CCRs have been created in this project, making it the nation's largest PHR effort to date.
- Intel Corporation, Adobe, the AAFP, and others are working on a new best practices standard called the PDF/H, which will "package" the CCR xml file in a user-friendly Adobe pdf document format. Adobe pdf is a very familiar and commonly used Internet document management standard that requires only the free ubiquitous Adobe Reader to view and manage documents securely.

# An Overview of the CCR-Based PHR Service Initiated At The New Orleans Health Recovery Week February 6 -12, 2006

Standards-based, portable, and  
private electronic personal health records  
for the citizens of New Orleans



# CCR Use in Quality, Safety, and Care Management

# As the basis for Personal Health Records, the Continuity of Care Record standard can empower the person/patient/consumer

- Keeping in mind that the CCR standard is quite new, as is the concept of a Personal Health Record, here are several ways in which the health care consumer can take advantage of these new technologies:
  - Get rid of the clipboard: Individuals who have their personal health information on a physical medium, e.g. USB drive, cell phone, or CD ROM, will be able to present this information to the ‘next provider’ whenever called upon to do so. If the PHR is also stored on a web server as a service, individuals can grant permission to providers to view the data in the CCR.
  - Automate health risk assessments: Individuals in possession of their personal health information in CCR format will be able to upload their data (de-identified) to server software that analyzes and reports back directly to the patient/person
    - risk factors associated with family history, social behaviors, and past medical experiences
    - suggested behavioral changes to address those risks
    - copies of reports and findings can be sent to the person’s caregivers and providers, and used as the basis for ongoing treatment or further assessment as indicated.
    - this process can be repeated as appropriate at minimal cost and with minimal new data entry.

# As the basis for Personal Health Records, the Continuity of Care Record standard can empower the person/patient/consumer, cont'd

- Consumer empowerment will include use of personal health information to:
  - search for and locate medical practices, e.g. those that offer EHRs, PHRs, and other online communications with patients, such as e-mail and lab results, that are user-friendly, convenient
  - search for and locate pharmacies, medical equipment, and other health care products and services that accept Medicare, Medicaid, or other insurance benefit plans
  - obtain quotes on prices for prescription medications from retail pharmacies and mail-order PBMs, while getting suggestions for replacement of brand name drugs with equally effective but much less expensive generics
  - find out about clinical trials and academic research programs that are looking to recruit patients with specific medical conditions and/or life-styles
  - automate reminders and alerts important in the management of both acute and chronic medical/surgical conditions, such as when to take medication on a schedule or obtain a blood or urine test

# CCR and other

# Core Structural Differences

Attribute	HL7 CDA/CRS	ASTM CCR
<b>Primary Use Case</b>	Standard for Single Event Clinical Document Structure	Standard for Data Aggregation Across Clinical Events for Clinical and Administrative Patient Summary
<b>Syntax</b>	XML	XML
<b>XML Use and Constraints</b>	Data In Tags and Tag Attributes - HL7 Specific Approach	Data Must Be Tagged - Tag Attributes Restricted To Processing Instructions - Adheres to Standard XML Practice in the General Computer Industry
<b>Data Constraints</b>	Local Extensions Allowed, Flexible Implementation Guide Allowing Customization, Free Text Required	<u>NO</u> Extensions Allowed, Extremely Strict Implementation Guide, Free Text Supported and Allowed, Structured Text Required Unless Unavailable
<b>Data/Object Model</b>	HL7 Reference Information Model (RIM) OMG-derived ER Object Model	XML Object Model - Uses XML as Syntax as Well as Object Description Language
<b>Architecture</b>	RIM is a Conceptual Data Model not a Production Data Model	CCR XML Object Model is Designed as a Production Object/Relational Data Model
<b>Security</b>	Not Yet Defined	W3C XML Encryption and Digital Signatures

# What are the real issues/differences...?

- **Technical**

- Difference of opinion regarding XML syntax...
- HL7 is an ER Object Model while the CCR is and Object/Relational Model...
- HL7 allows customization and local extensions, CCR does not...
- HL7 XML syntax is less efficient for processing...
- HL7 RIM is not designed to be a production data model, CCR Object/Relational Model is...

- **Political**

- HL7 has significantly more clout in the legacy vendor community and within the Federal Government...
- HL7 views the CCR as a core threat to its clinical message standards domain...
- HL7 and ASTM have a long history of cooperation mixed with animosity...
- HL7 is the domain of the big vendors and institutions, ASTM the mid-tier and smaller, progressive vendors and the medical specialty societies...
- HL7 is backed (partially) by the ACP, ASTM by the AAFP, AAP, APA, ANA, ACOG and others...

**Digoxin 0.125mg, 1 PO qDay, #90, 5 refills.**

```
<section>
  <text>Digoxin 0.125mg, 1 PO qDay, #90, 5 refills.</text>
  <entry>
    <substanceAdministration classCode="SBADM" moodCode="RQO">
      <effectiveTime xsi:type="PIVL_TS">
        <period value="24" unit="h"/>
      </effectiveTime>
      <routeCode code="PO" codeSystem="2.16.840.1.113883.5.112"/>
      <doseQuantity value="1"/>
      <consumable>
        <manufacturedProduct>
          <manufacturedLabeledDrug>
            <code code="317896006" codeSystem="2.16.840.1.113883.6.96"
              displayName="Digoxin 125micrograms tablet"/>
          </manufacturedLabeledDrug>
        </manufacturedProduct>
      </consumable>
      <entryRelationship typeCode="COMP">
        <supply classCode="SPLY" moodCode="RQO">
          <repeatNumber><low value="0"/><high value="5"/></repeatNumber>
          <independentInd value="false"/>
          <quantity value="90"/>
        </supply>
      </entryRelationship>
    </substanceAdministration>
  </entry>
</section>
```

**Digoxin 0.125mg, 1 PO qDay, #90, 5 refills.**

```
<Medications>
  <Medication>
    <Description>
      <Text>Digoxin 0.125mg, 1 PO qDay, #90, 5 refills</Text>
    </Description>
    <Product>
      <ProductName>Digoxin</ProductName>
      <Strength>
        <Value>0.125</Value>
        <Units>mg</Units>
      </Strength>
    </Product>
    <Quantity>
      <Value>90</Value>
    </Quantity>
    <Directions>
      <Direction>
        <Dose>
          <Value>1</Value>
        </Dose>
        <Route>
          <Text>po</Text>
        </Route>
        <Frequency>
          <Value>qd</Value>
        </Frequency>
      </Direction>
    </Directions>
    <Refills>
      <Refill>
        <Number>5</Number>
      </Refill>
    </Refills>
  </Medication>
```

# Structural Overview

**Inpatient Chart**

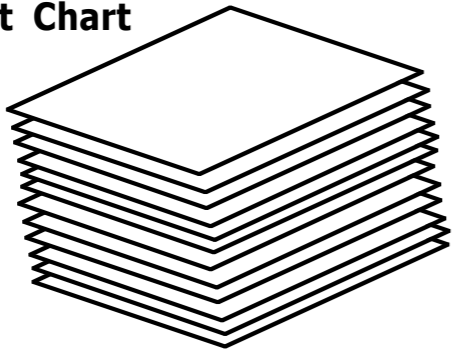

**Clinic Chart**

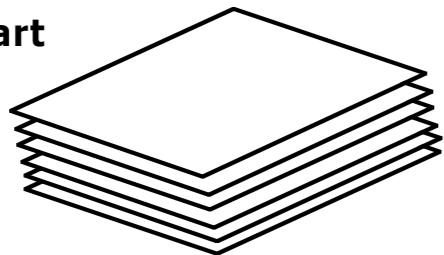

**Consult Note**

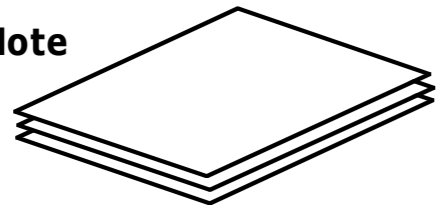

**PHR/Patient**

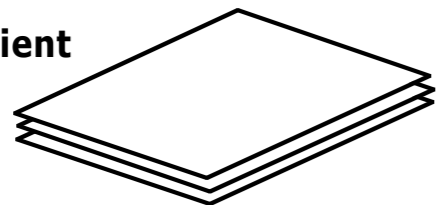

**CCR** II/09/2005

---

**Problems**  
 3/11/04 Myocardial Infarction – Anterior Septal  
 9/18/92 CVA – Right Middle Cerebral Artery Infarct

**Medications**  
 Atenolol 25mg po bid (3/12/04) Last Fill 3/1/05  
 Coumadin 5mg qd M/W/F (3/1/05) Last Fill 3/1/05  
 Coumadin 7.5mg T/Th/Sat/Sun (3/1/05) Last Fill 3/1/05

---

Doe, John Quincy  
 Medical Record # 0005769896  
 Date of Birth 01/09/1965

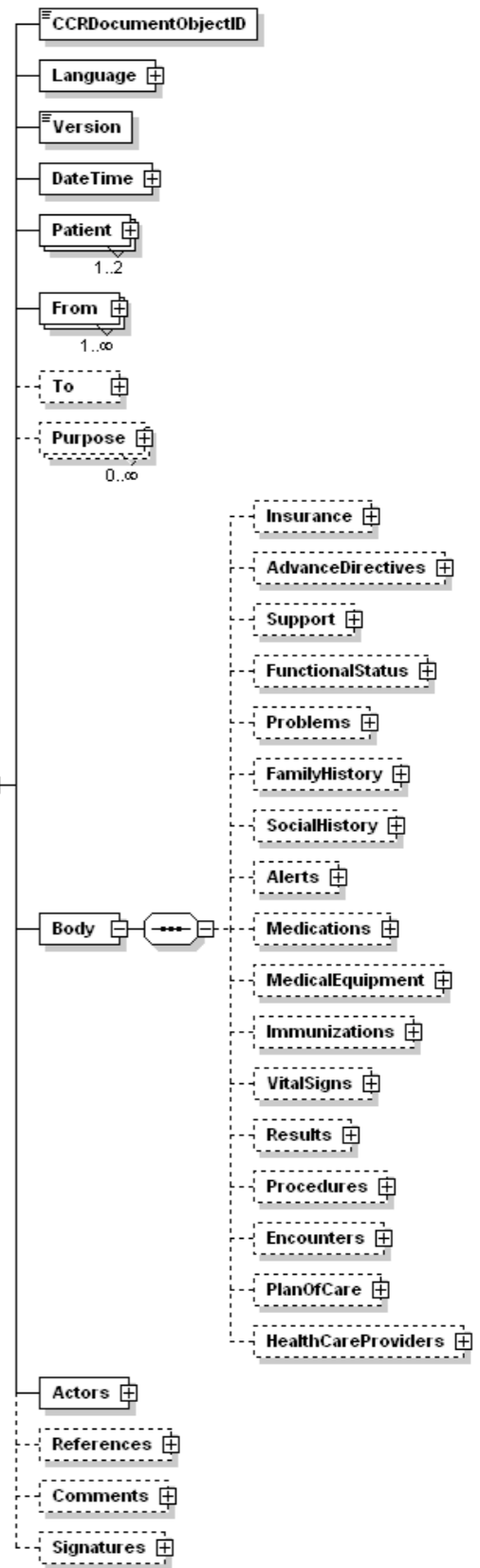



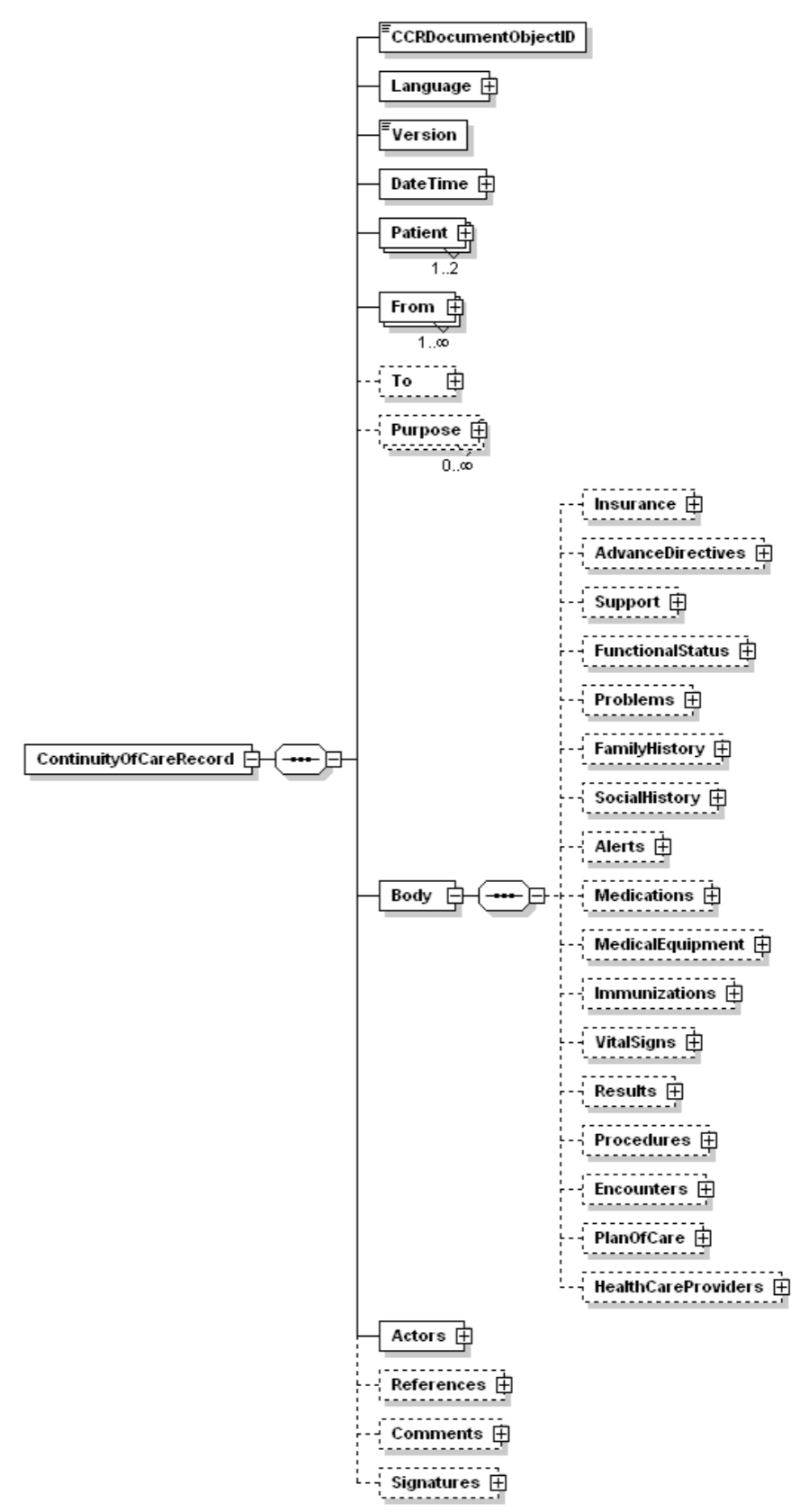
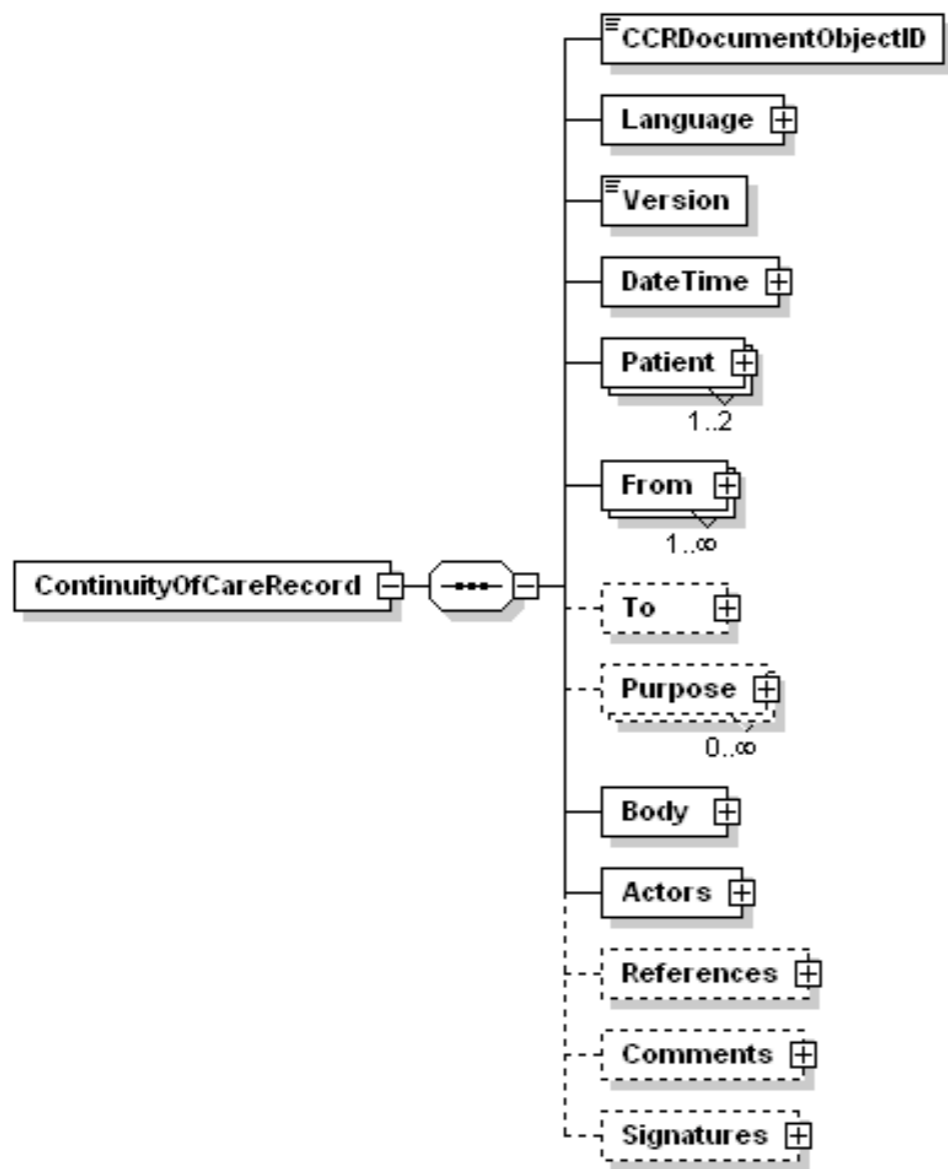

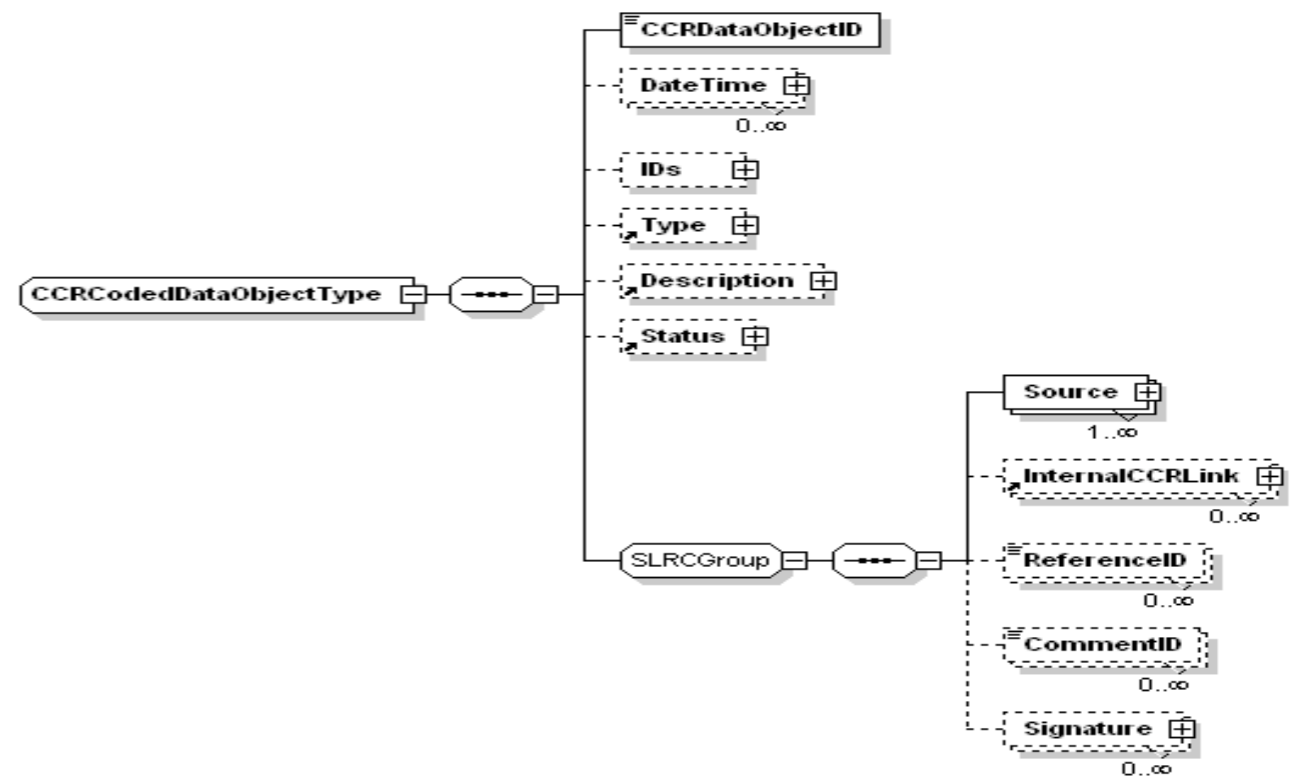
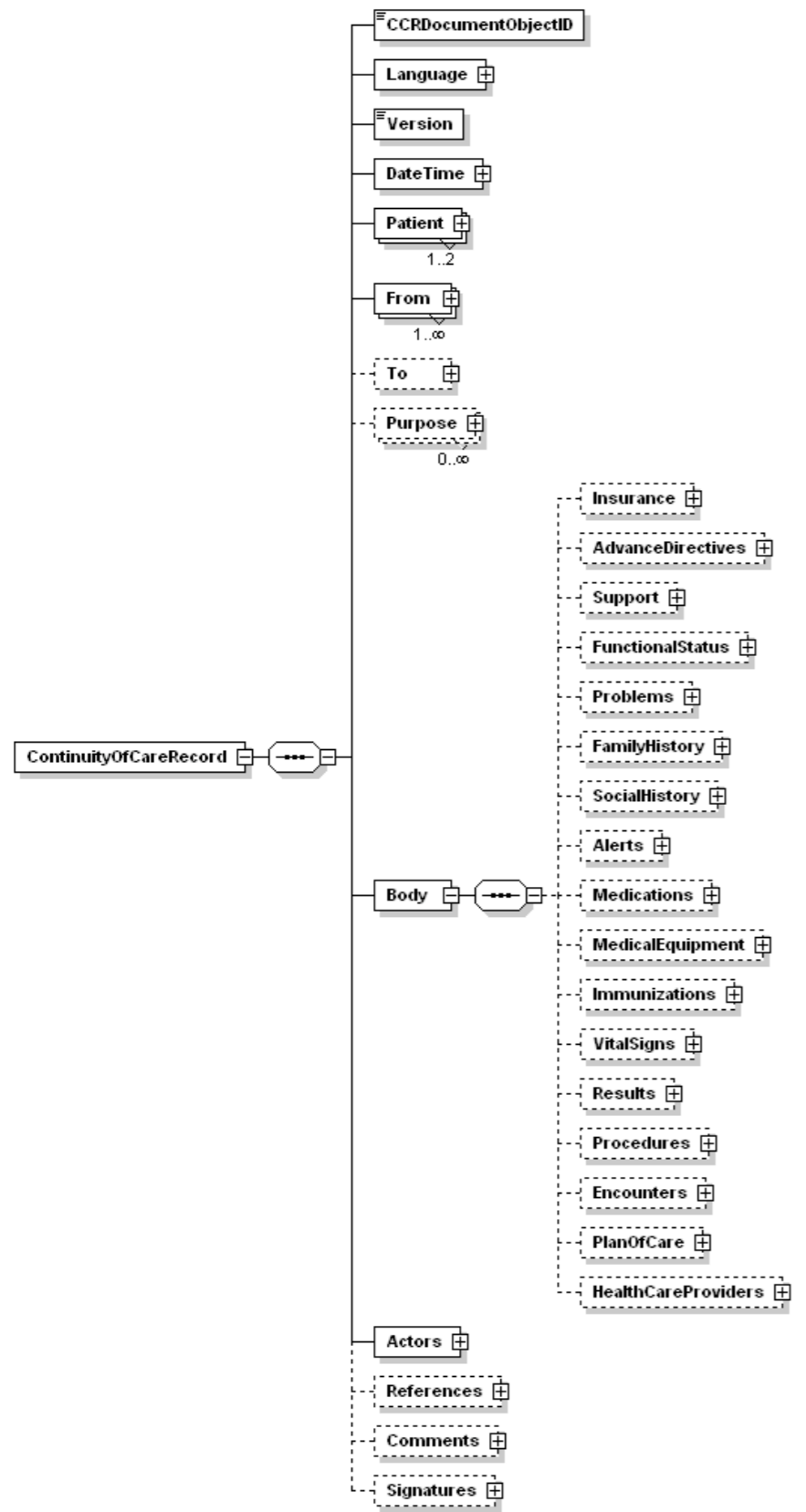

Generated with XMLSpy Schema Editor www.altova.com

